

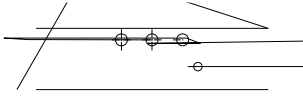
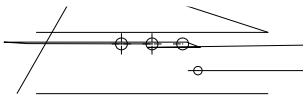

Package	Tape Width	Reel Size	Pitch	Packaging Quantity			Tape Orientation	OPN Suffix
	mm	inch		mm	Reel	Inner Box	Carton	
				kpcs	kpcs	kpcs		
SOD-123	8	7	4	3	30	120		-F2
		13	4	10	NA	210		-F3

Note 1: These are minimum package quantities only. Minimum order quantities may vary. Please contact your sales representative for more information on minimum order quantities.

Note 2: YJ Tape&reel products meets EIA-481 specification.

Note 3: Please refer to the product datasheet for MSL level, RoHS and Halogen-Free compliance.



Tape Width	A0(mm)	B0(mm)	B1(mm)	E(mm)	F(mm)	P0(mm)
8mm		Note4	Note5	1.75	3.5	4

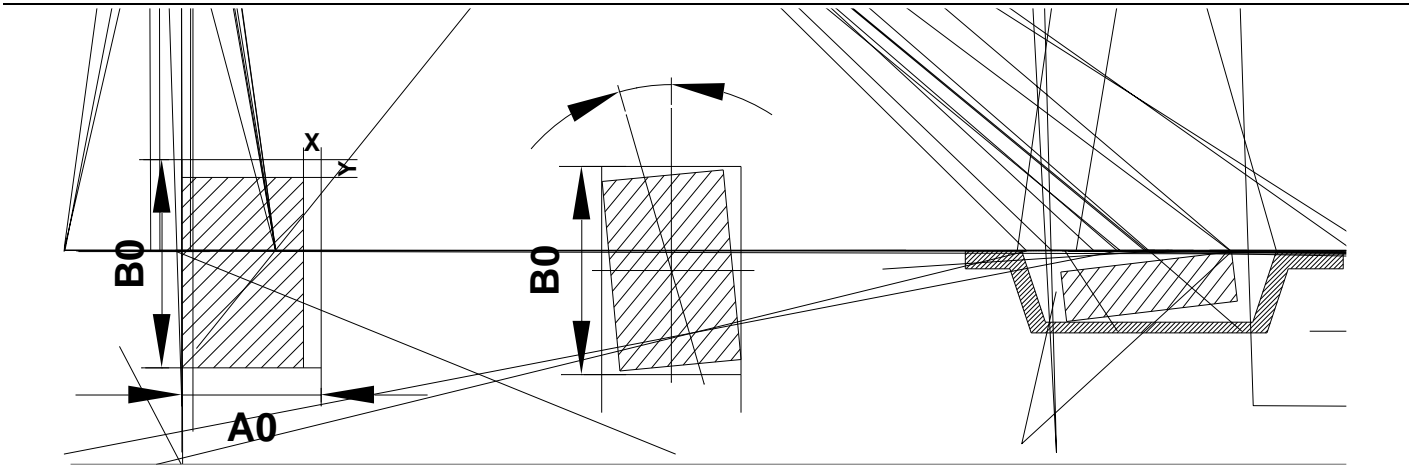

Tape width	8,12mm
X(mm)	0.5
Y(mm)	0.5

Maximum Component Rotation		
Tape width	Top View	Side View
Mm		s
8 12	20	20

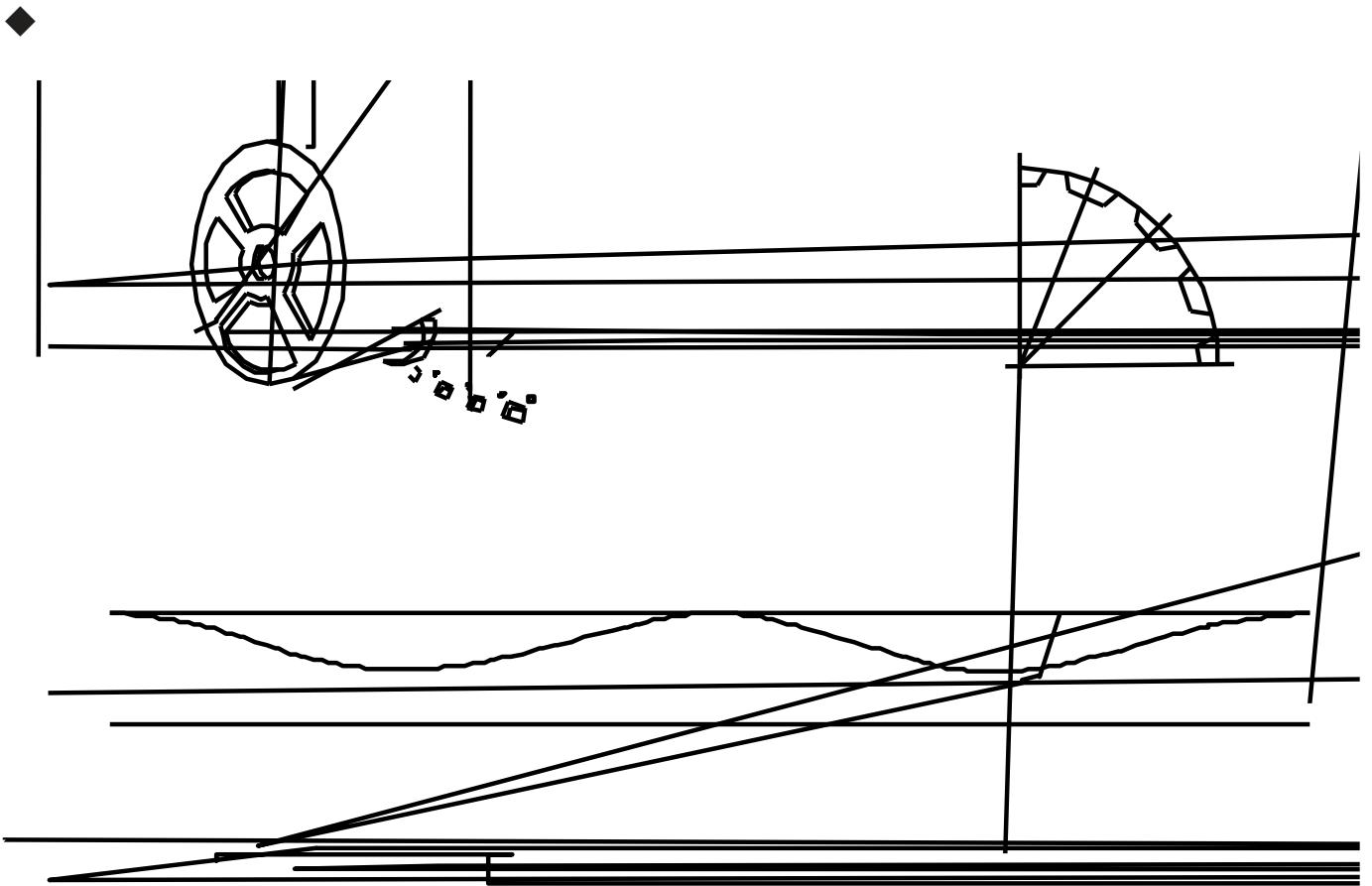

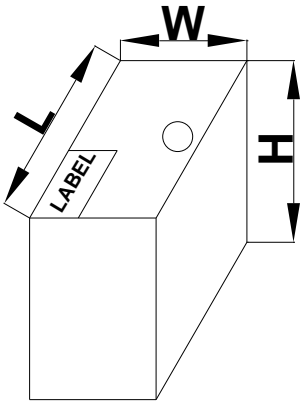

Dimension	Specification(mm typical)
Reel Size	7 inch
L	187±2
W	130±2
H	187±2

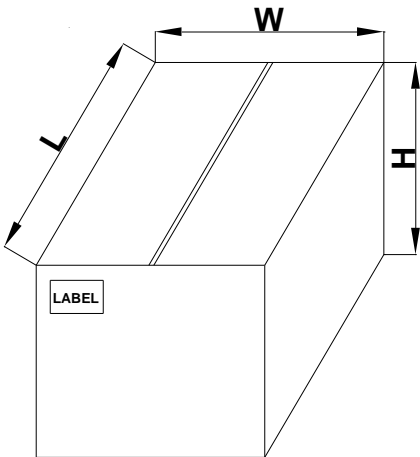

Dimension	Specification(mm typical)	
Reel Size	7 inch	13 inch
L	390±5	355±5
W	275±5	345±5
H	207±5	290±5