



YJG150N03A

N-Channel Enhancement Mode Field Effect Transistor

Product Summary

V_{DS}	30 V
I_D	150 A
$R_{DS(ON)}$ (at $V_{GS}=10V$)	2.0 mohm
$R_{DS(ON)}$ (at $V_{GS}=4.5V$)	3.3 mohm
100% EAS Tested	
100% V_{DS} Tested	

General Description

Trench Power MV MOSFET technology
Excellent package for heat dissipation
High density cell design for low $R_{DS(ON)}$
Moisture Sensitivity Level 1
Epoxy Meets UL 94 V-0 Flammability Rating
Halogen Free

Applications

DC-DC Converters
Power management functions
Backlighting

Absolute Maximum Ratings ($T_A=25$ unless otherwise noted)

	Symbol	Limit	Unit
Drain-source Voltage	V_{DS}	30	V

YJG150N0



Typical Performance Characteristics

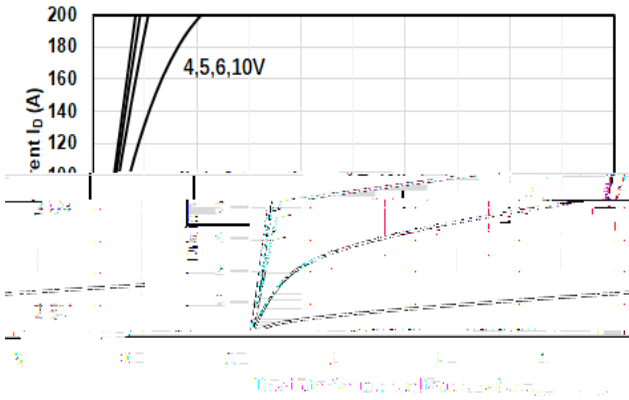

Figure1. Output Characteristics

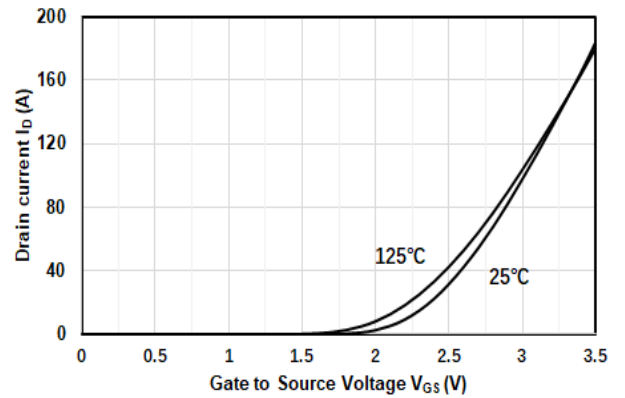

Figure2. Transfer Characteristics

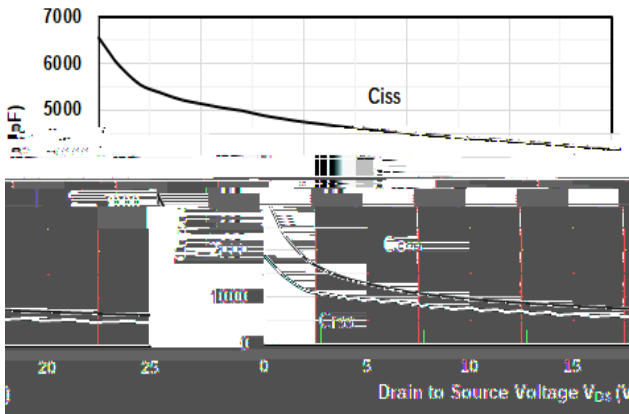

Figure3. Capacitance Characteristics

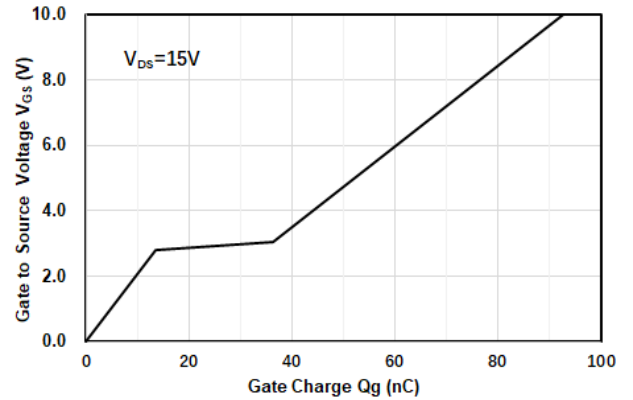

Figure4. Gate Charge

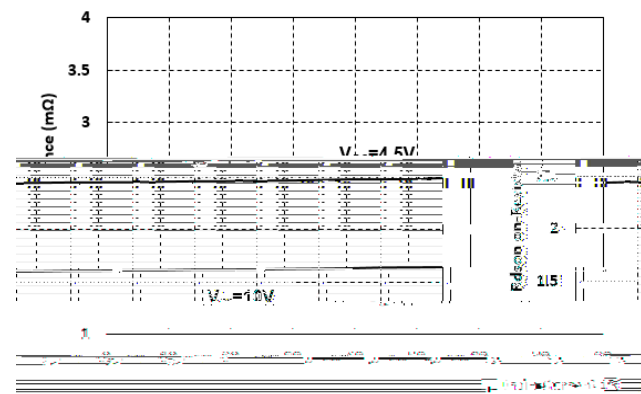

Figure5. Drain-Source on Resistance

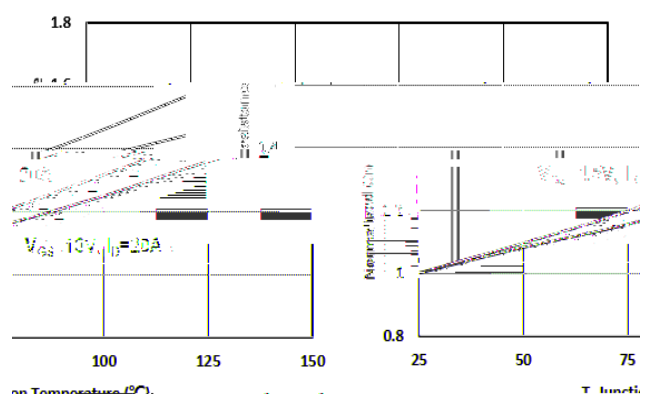

Figure6. Drain-Source on Resistance

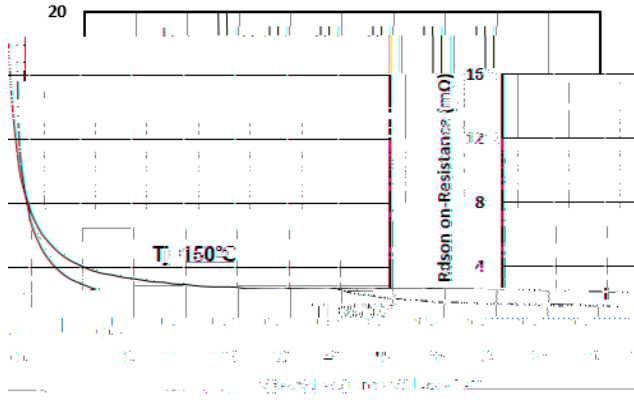

Figure7. On-Resistance vs Vgs

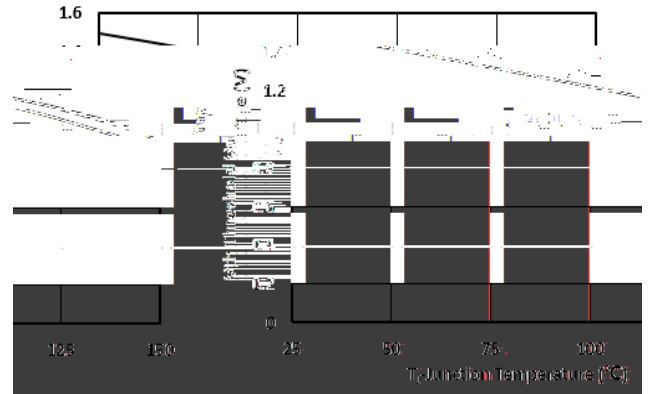

Figure8. Vth vs Temperature

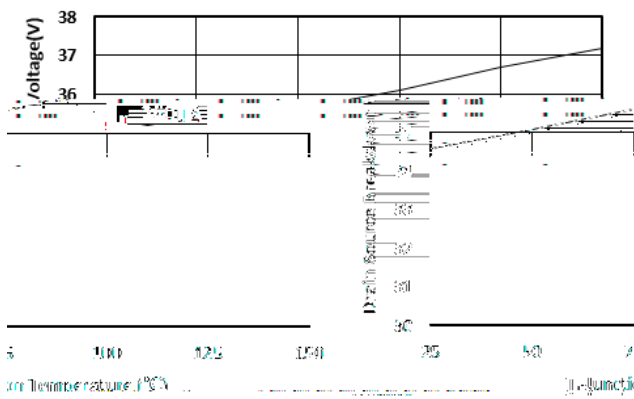

Figure9. Breakdown Voltage vs Temperature

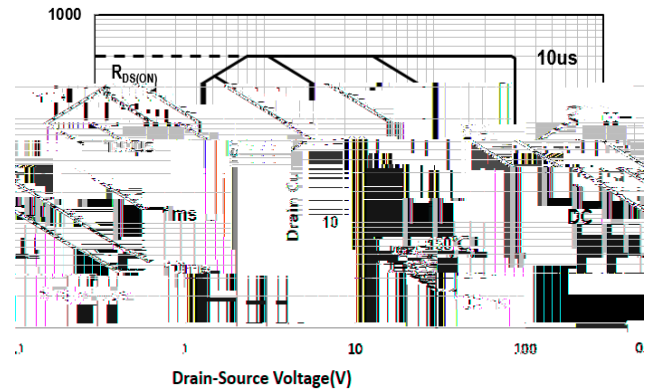

Figure10. Safe Operation Area

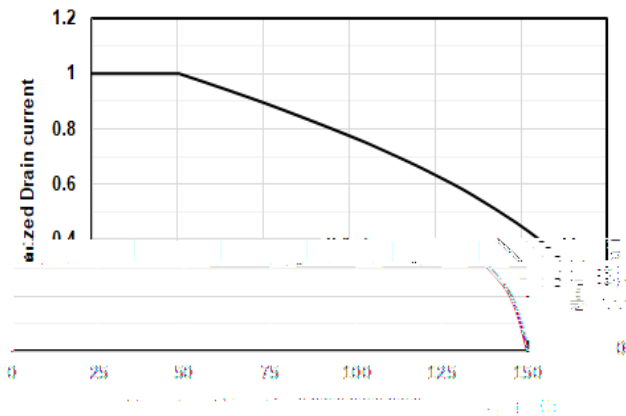

Figure11. Drain current vs. Case Temperature

YJG150



YJG150N03A

PDFN5060-8L-B-1.1MM Package Information

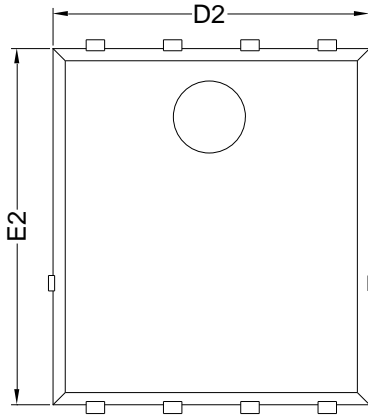

Top View

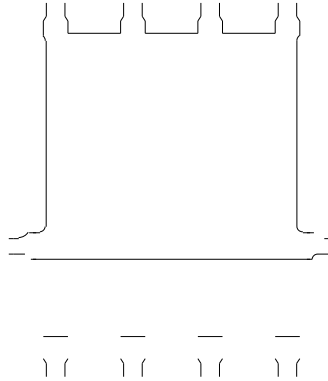

Bottom View

Side View

SYMBOL	MILLIMETER		
	MIN	NOM	MAX
D	5.15	5.35	5.55
E	5.95	6.15	6.35
A	1.00	1.10	1.20
A1	0.254 BSC		
A2			0.10
D1	3.92	4.12	4.32
E1	3.52	3.72	3.92
D2	5.00	5.20	5.40
E2	5.66	5.86	6.06
E3	0.254 REF		
E4	0.21 REF		
L1	0.56	0.66	0.76
L2	0.50 BSC		
b	0.31	0.41	0.51
e	1.27 BSC		

Note:

1. Controlling dimension: in millimeters.
2. General tolerance: ± 0.10 mm.
3. The pad layout is for reference purposes only.



Disclaimer